

# A Rational Approach to Fire Resistance Analysis of Reinforced Concrete Columns Subjected to Uniaxial/Biaxial Bending and Axial Restraint

Truong Thang Nguyen, Kang Hai Tan

## Motivation

In extensive published research works on fire resistance of reinforced concrete (RC) columns: (1) Concentric load and eccentric load with uniaxial bending have been mostly concerned. For biaxially-loaded columns, an indirect approach using Bresler's formula was proposed (Tan and Yao, 2003); (2) Additional axial forces due to axial restraint were rarely considered; (3) Fire resistance was usually validated by comparing the ultimate loads predicted and measured at a given failure time in fire tests following a standard fire curve; and (4) Limited information of fire tests on biaxially-loaded columns have been used for verification.

## Proposed Approach

By conducting the temperature-dependent sectional analysis based on inclined neutral axes, fire resistance of axially-restrained RC columns subjected to uniaxial/biaxial bending in either non-standard or standard fires can be determined as the failure time with the most possible failure criterion, i.e when the increased acting load reaches either buckling or ultimate capacity of the column at elevated temperatures. The computer-based approach was well validated by experimental data obtained from both Technical University of Braunschweig (Hass, 1986) and Nanyang Technological University (NTU) in 2010.

## Methodology

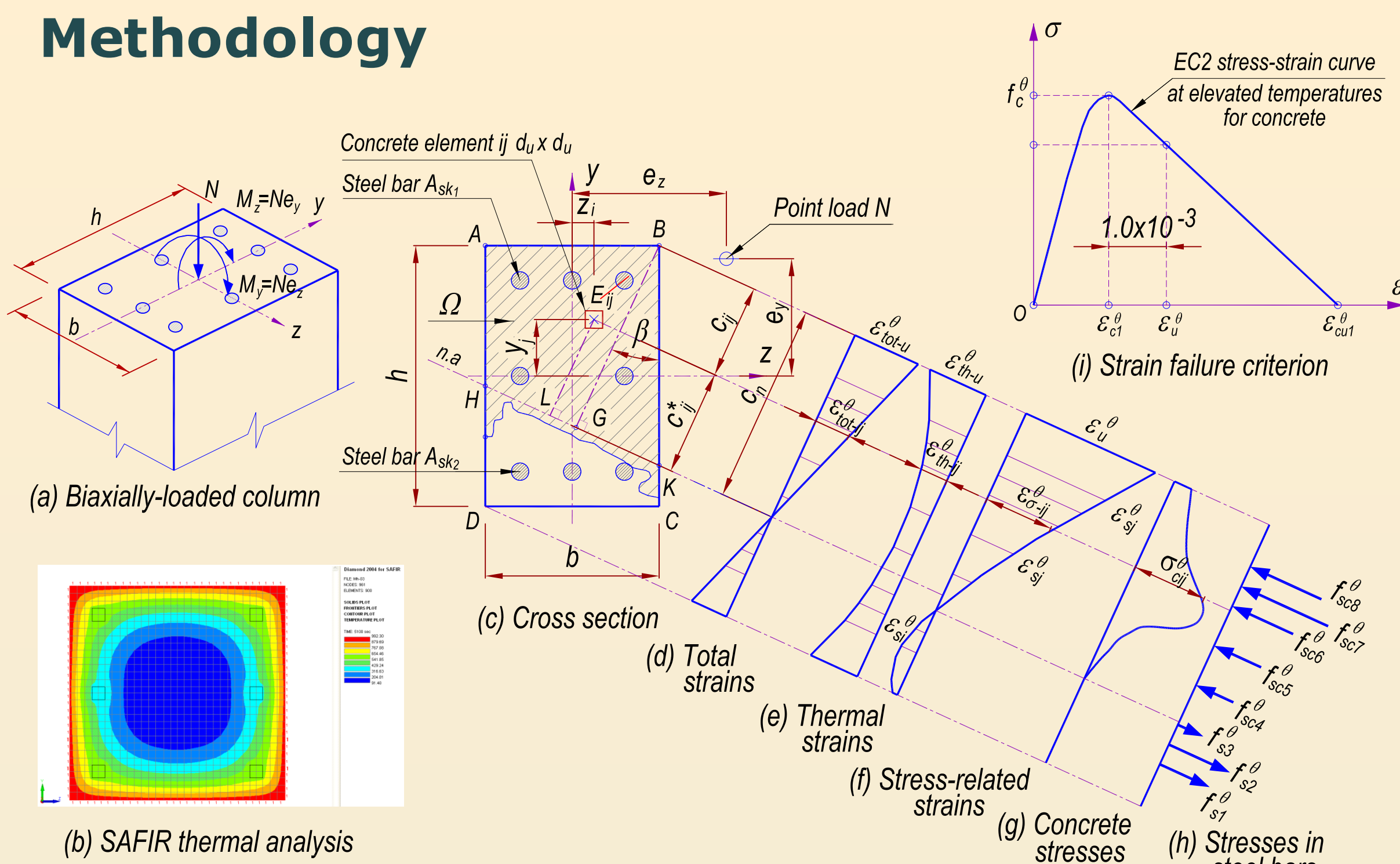

FIG. 1. Direct sectional analysis to determine the column load resistance at elevated temperatures

$$N_{Rd}^0 = \sum \sigma_{ij}^0 d_u^2 + \sum A_{sk_i} (f_{sk_i}^0 - \sigma_{ck_i}^0) + \sum A_{sk_j} f_{sk_j}^0$$

$$M_{Rd_y}^0 = \sum \sigma_{ij}^0 d_u^2 z_i + \sum A_{sk_i} (f_{sk_i}^0 - \sigma_{ck_i}^0) z_{k_i} + \sum A_{sk_j} f_{sk_j}^0 z_{k_j}$$

$$M_{Rd_z}^0 = \sum \sigma_{ij}^0 d_u^2 y_j + \sum A_{sk_i} (f_{sk_i}^0 - \sigma_{ck_i}^0) y_{k_i} + \sum A_{sk_j} f_{sk_j}^0 y_{k_j}$$

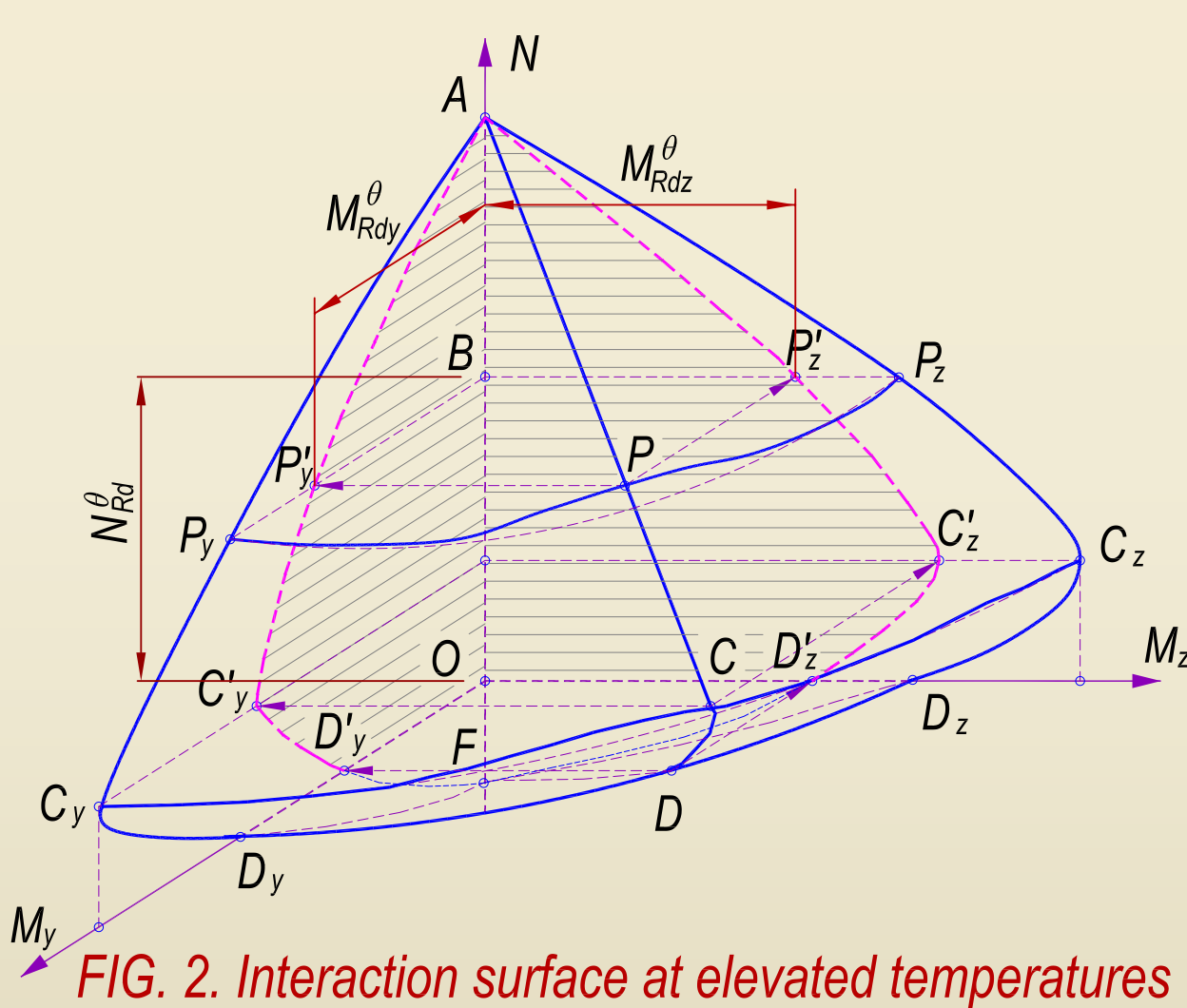

FIG. 2. Interaction surface at elevated temperatures

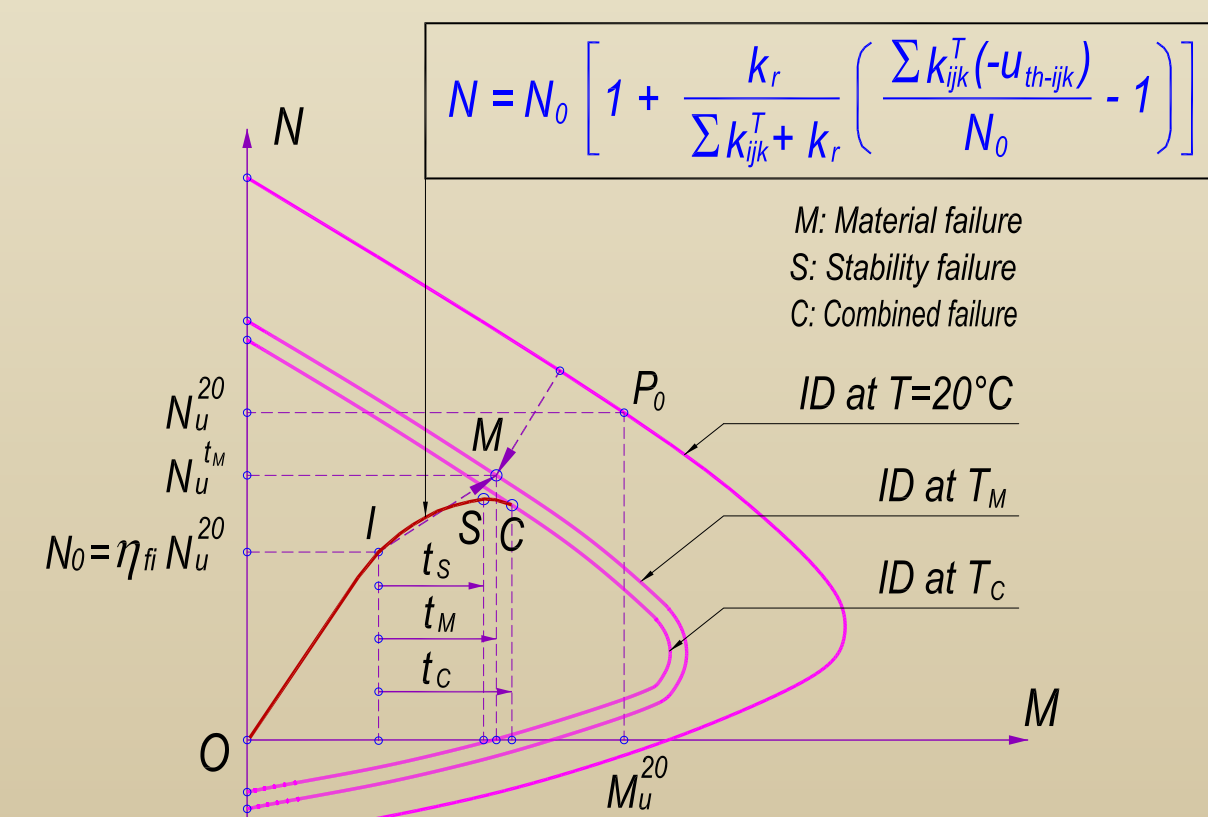

FIG. 3. Failure criteria

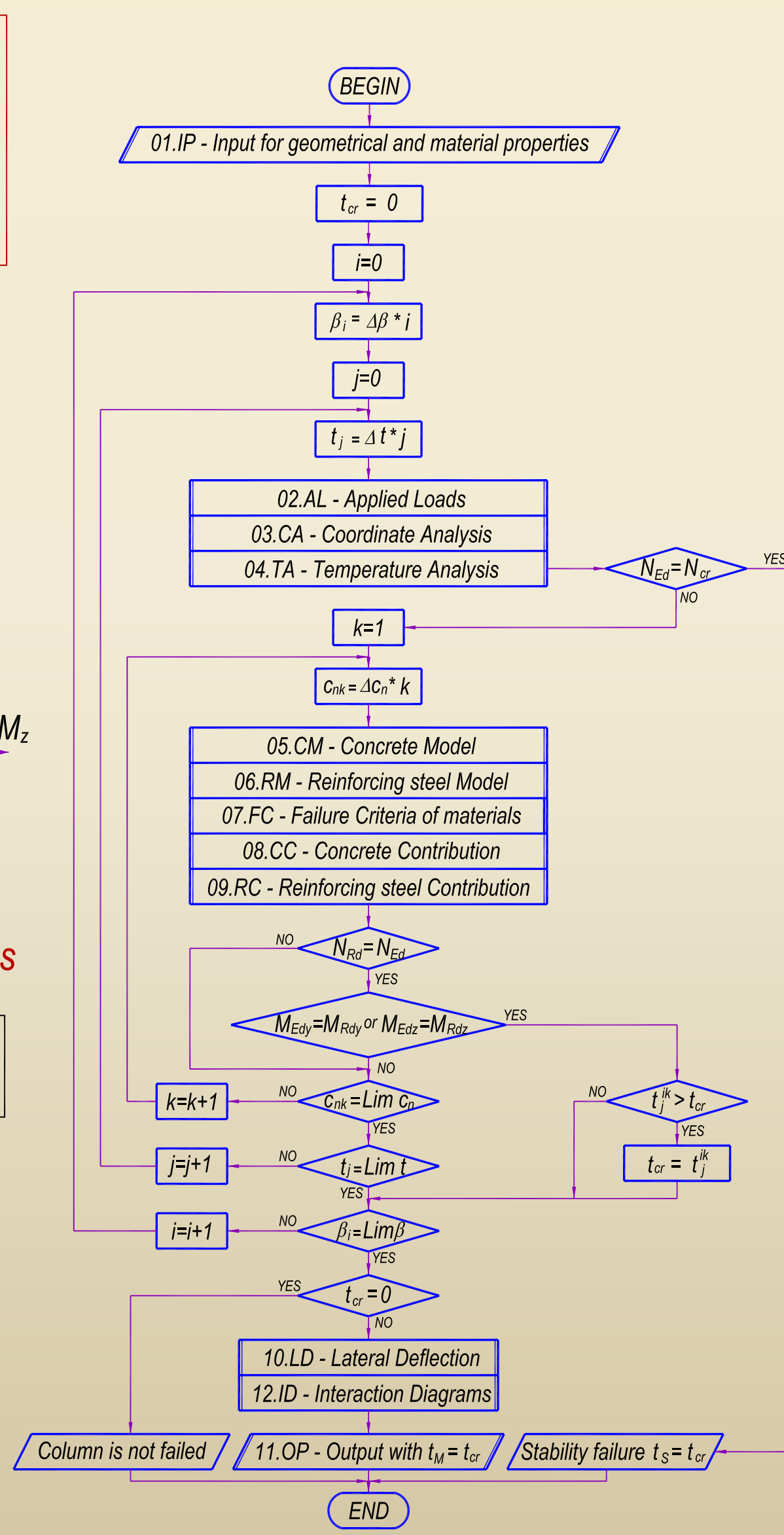
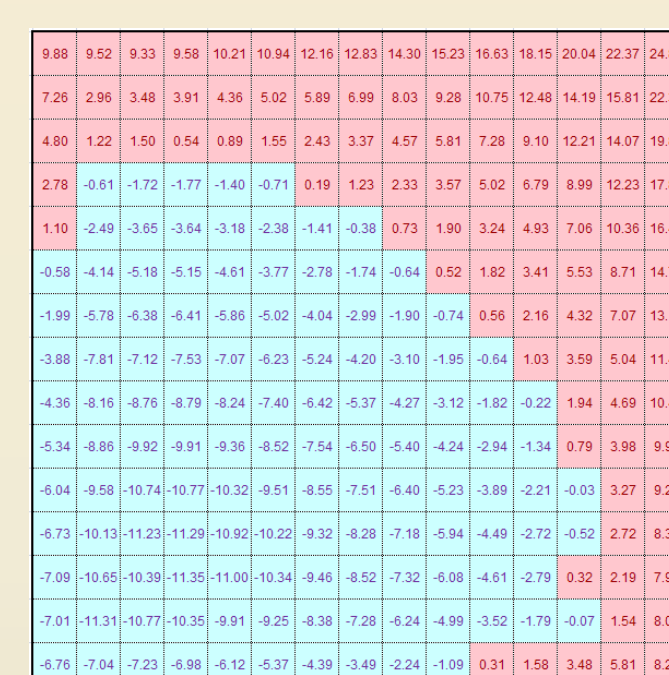

FIG. 4. Flowchart of FRRC program

## Experimental Verification

TAB. 1. Experimental verification

| Test        | No. | Ref. | Experimental Data |        |            |       |           |          |           |         |         |         |            | Proposed Approach |             | Ratio |         |         |             |
|-------------|-----|------|-------------------|--------|------------|-------|-----------|----------|-----------|---------|---------|---------|------------|-------------------|-------------|-------|---------|---------|-------------|
|             |     |      | b (mm)            | h (mm) | Rebar (mm) | L (m) | f'c (MPa) | fy (MPa) | End Cond. | d' (mm) | ey (mm) | ez (mm) | kr (kN/mm) | Napp (kN)         | tTest (min) |       | β (rad) | Cn (mm) | tFRRC (min) |
| Hass (1986) | 1   | 1    | 300               | 300    | 6φ20       | 3.76  | 24.1      | 487      | p-p       | 38      | 30      | 0       | 0          | 710               | 86          | 0     | 126     | 85      | 0.988       |
|             | 2   | 2    | 300               | 300    | 6φ20       | 3.76  | 24.1      | 487      | p-p       | 38      | 0       | 0       | 0          | 930               | 84          | 0     | 150     | 82      | 0.976       |
|             | 10  | 10   | 200               | 200    | 4φ20       | 4.76  | 24.1      | 487      | p-p       | 38      | 0       | 0       | 0          | 340               | 48          | 0     | 100     | 39      | 0.813       |
|             | 20  | 20   | 300               | 300    | 6φ20       | 3.8   | 33.2      | 458      | p-f       | 38      | 30      | 0       | 0          | 845               | 111         | 0     | 130     | 94      | 0.847       |
|             | 27  | 30   | 300               | 300    | 6φ20       | 4.76  | 38.2      | 404      | p-p       | 38      | 5       | 0       | 0          | 1224              | 48          | 0     | 150     | 55      | 1.146       |
|             | 33  | 41   | 300               | 300    | 6φ20       | 4.70  | 31.5      | 526      | p-p       | 38      | 150     | 0       | 0          | 465               | 50          | 0     | 120     | 45      | 0.900       |
| NTU (2010)  | 1   | C1-3 | 300               | 300    | 6φ20       | 3.54  | 55.3      | 550.2    | p-p       | 40      | 25      | 0       | 31.43      | 1700              | 166         | 0     | 150     | 190     | 1.145       |
|             | 2   | C1-4 | 300               | 300    | 6φ20       | 3.54  | 55.3      | 550.2    | p-p       | 40      | 40      | 0       | 31.43      | 1400              | 211         | 0     | 130     | 190     | 0.900       |
|             | 3   | C1-5 | 300               | 300    | 6φ20       | 3.54  | 55.3      | 550.2    | p-p       | 40      | 60      | 0       | 31.43      | 1100              | 159         | 0     | 120     | 196     | 1.233       |
|             | 4   | C2-1 | 300               | 300    | 6φ20       | 3.54  | 55.3      | 550.2    | p-p       | 40      | 25      | 25      | 30.40      | 1150              | 182         | 0.733 | 170     | 194     | 1.069       |
|             | 5   | C2-2 | 300               | 300    | 6φ20       | 3.54  | 55.3      | 550.2    | p-p       | 40      | 40      | 40      | 30.40      | 920               | 189         | 0.733 | 160     | 202     | 1.069       |
|             | 6   | C2-3 | 300               | 300    | 6φ20       | 3.54  | 55.3      | 550.2    | p-p       | 40      | 60      | 60      | 30.40      | 650               | 176         | 0.733 | 150     | 208     | 1.182       |



(a) Strain (x0.001)

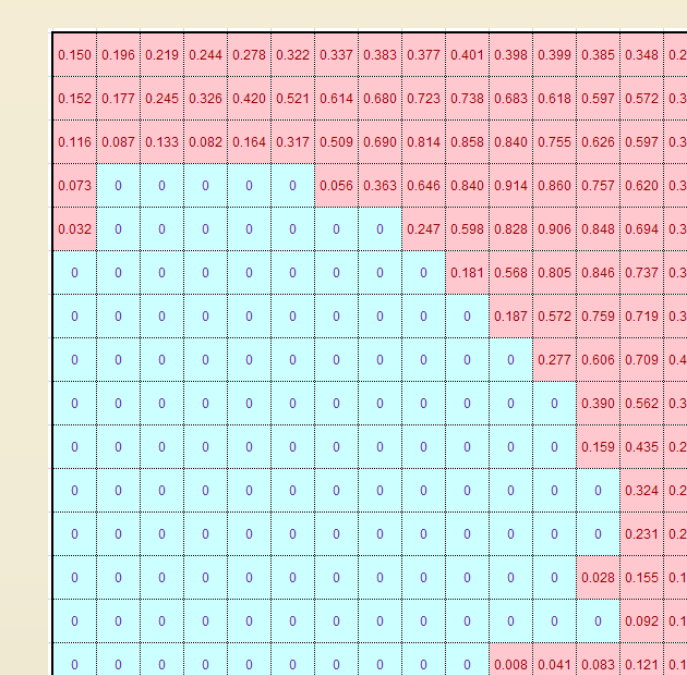

(b) Stress / Ambient strength

FIG. 5. Strain and stress distributions in concrete at failure

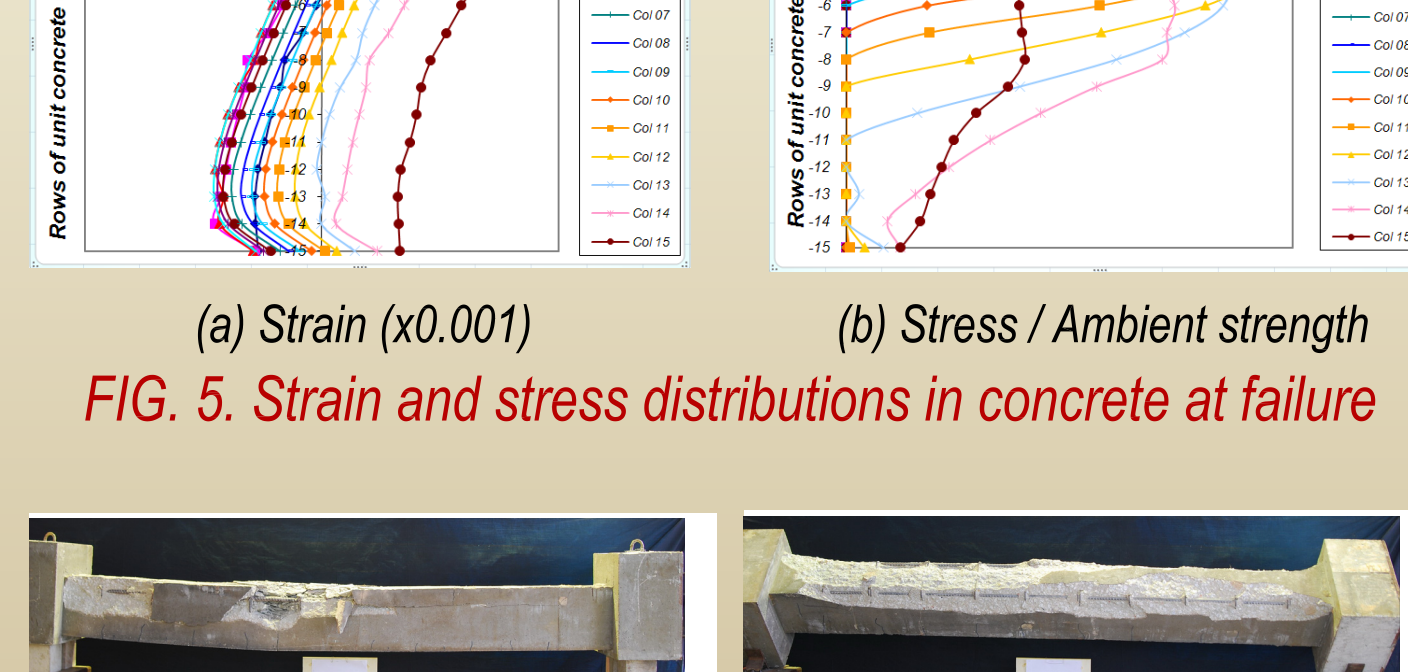

FIG. 6. Fire tests conducted in NTU (2010)

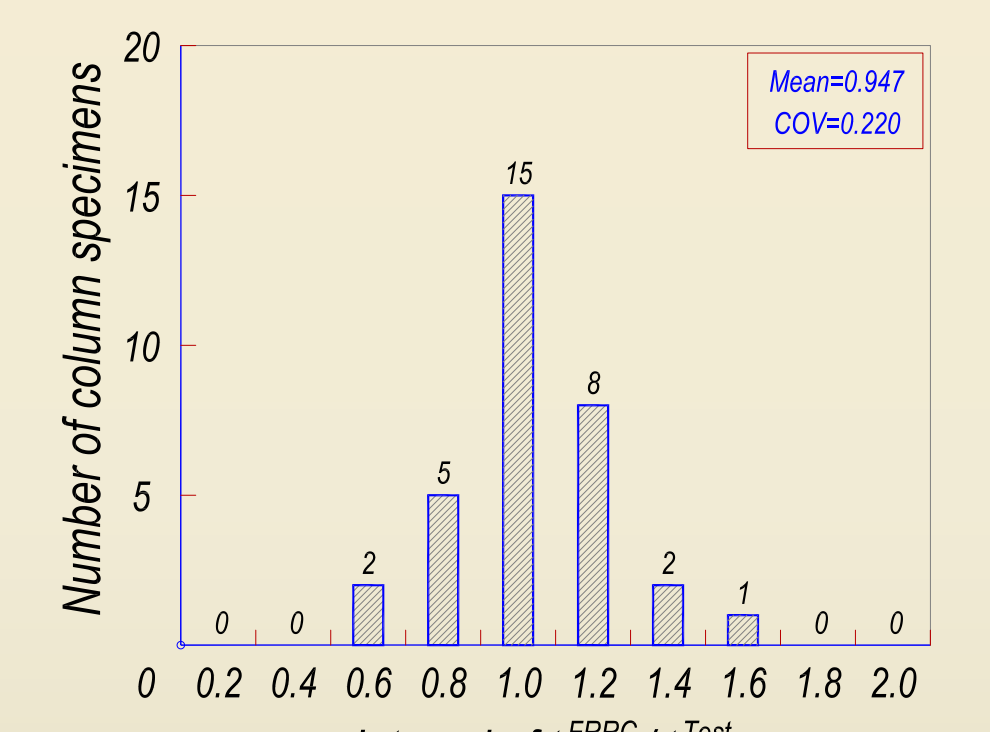

FIG. 7. Validation used Hass's tests (1986)

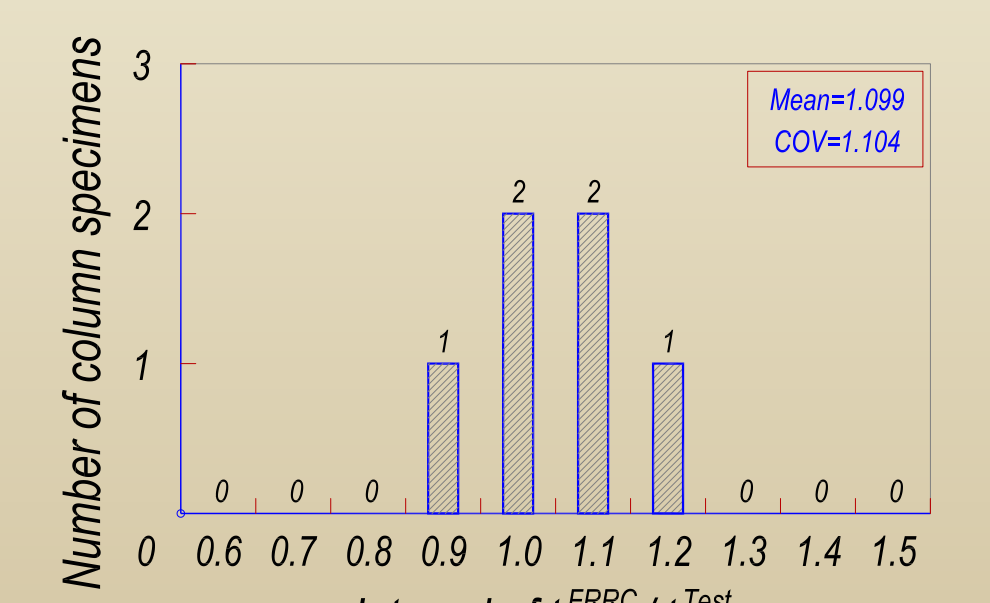

FIG. 8. Validation used NTU's tests (2010)

## Summary and Acknowledgement

Good agreement in failure times predicted by the proposed approach and measured in fire tests can be obtained. More conservative results were observed from the case of columns without axial restraint. Transient strain in concrete at elevated temperatures shall be considered in future research works.

This research was funded by grant M47030016 A\*STAR and supported by manpower research account MINDEF-NTU/JPP/FY05/14.

## References

Tan, K. H., Yao, Y., Fire Resistance of Four-Face Heated Reinforced Concrete Columns, *Journal of Structural Engineering*, 129(9), 1220-1229, 2003; Hass, R., *Practical Rules for the Design of Reinforced Concrete and Composite Columns Submitted to Fire*, Institute für Baustoffe, Massivbau und brandschutz der Technischen Universita Braunschweig, 1986; Frassen, J. M., *SAFIR. A Thermal/Structural Program Modelling Structures under Fire*, *Engineering Journal*, A.I.S.C., 42, 3: 143-158, 2005; Eurocode EN 1991-1-2:2004, *Design of Concrete Structures – Part 1-2: General Rules, Structural Fire Design*, 2004b.