



Shear Panel Components in the Vicinity of Beam-column Connections in Fire

Guan Quan
University of Sheffield



What is Shear Buckling?



Shear Buckling Near the Beam-Column Connection
Primary Beam Shear Buckling
Secondary Beam Shear Buckling



What is Shear Buckling?

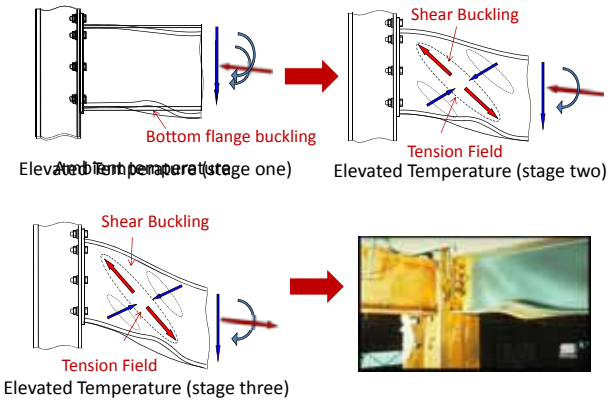

Why Create Shear Panel Elements?

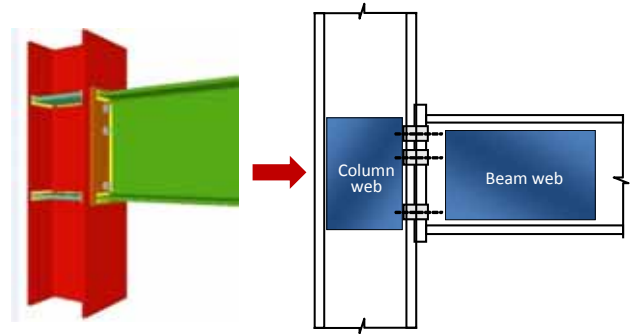

Why Create Shear Panel Elements?

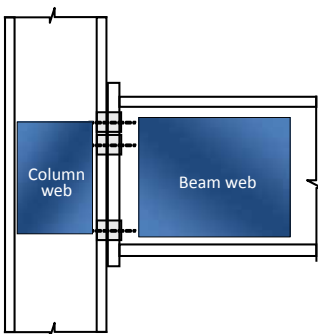

Why Create Shear Panel Elements?

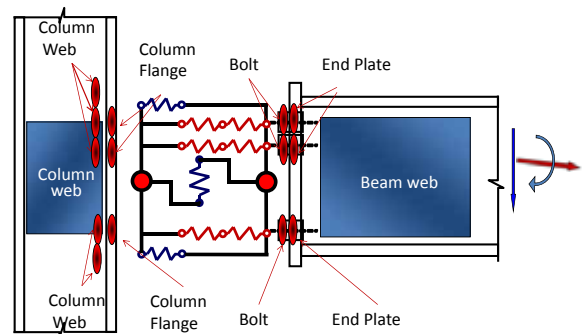

Why Create Shear Panel Elements?

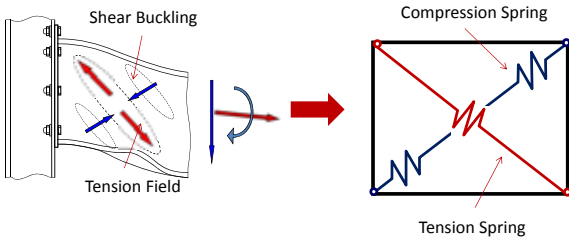

Why Create Shear Panel Elements?

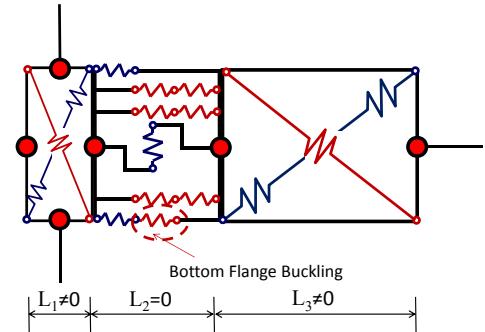

Why Create Shear Panel Elements?

- > Influence deflection
- > Stress redistribution

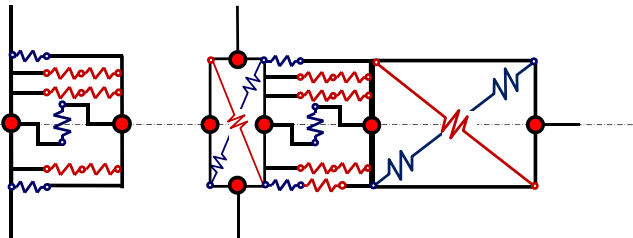

Why Create Shear Panel Elements?

- > Influence deflection
- > Stress redistribution

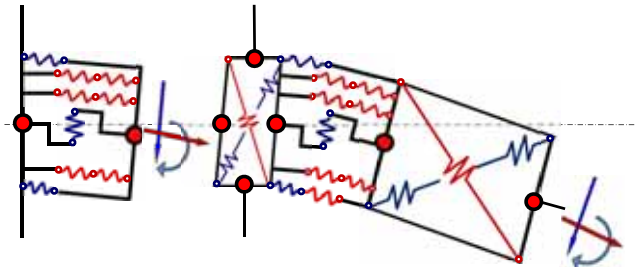

Why Create Shear Panel Elements?

- > Influence deflection
- > Stress redistribution

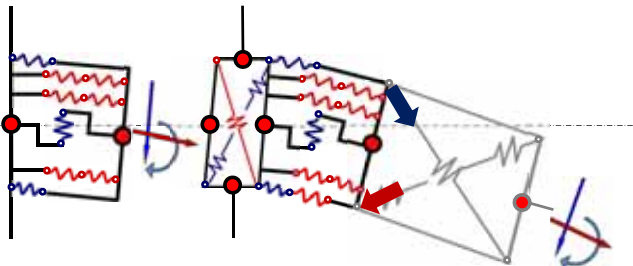

How to Create Shear Panel Elements?

**Newly Defined Shear Panel Model
at Ambient Temperature**



How to Create Shear Panel Elements?

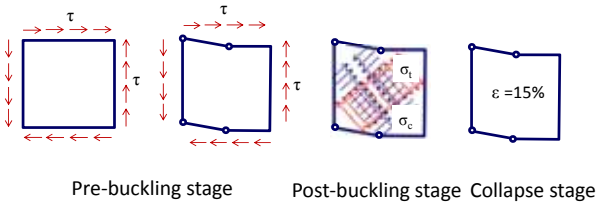

How to Create Shear Panel Elements?

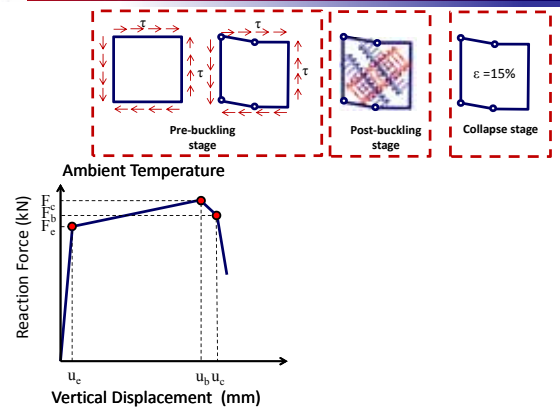

How to Create Shear Panel Elements?

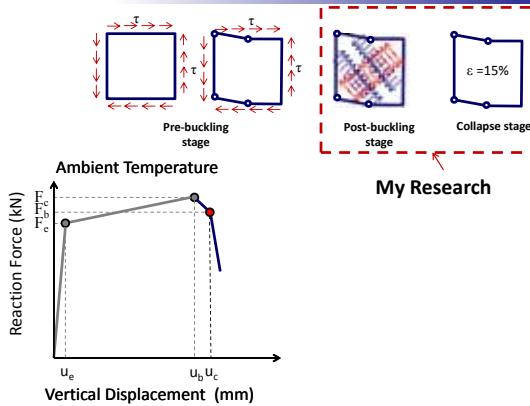

How to Create Shear Panel Elements?

The Length of Shear Panel

Shear Panel is a Square Panel

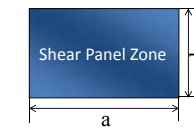

$$\tau_{cr} = K \frac{\pi^2}{12(1-\nu^2)} \left(\frac{t}{b}\right)^2$$

t : web thickness
 b : web height

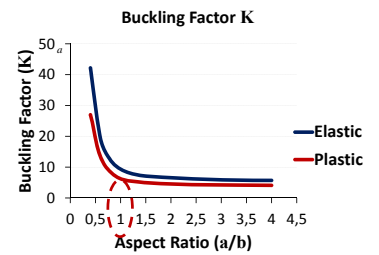

How to Create Shear Panel Elements?

Post-buckling Stage

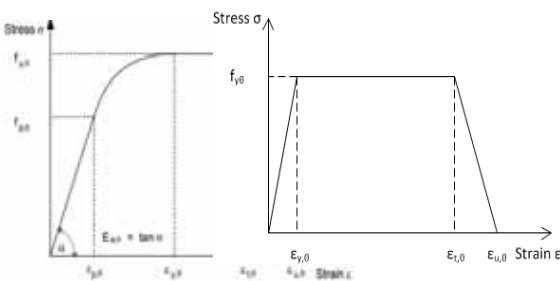

How to Create Shear Panel Elements?

The Internal Work of Web

EN 1993-1-6

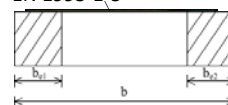

$$\sigma_x = 0.461\sigma_y \quad \sigma_z = 0.667\sigma_y$$

$$W_w = W_c + W_T$$

$$= \frac{0.687\sigma_y t d \sin \alpha \cos(\alpha + \theta) + 0.461\sigma_y t d \cos \alpha \sin(\alpha + \theta)}{\cos \theta}$$

$$= \frac{\sigma_y t d}{\cos \theta} (0.574 - 0.113 \sin \theta) \Delta$$

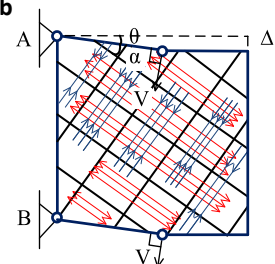



How to Create Shear Panel Elements?

The Internal Work of Flanges

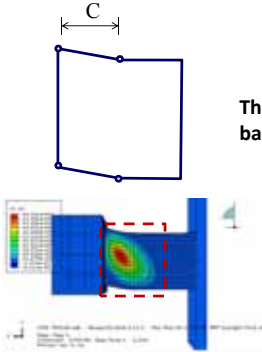

$$M = \frac{1}{4} \sigma_y b_f t_f^2$$

The influence of moment on
bending capacity of flanges

$$M' = M_f \left[1 - \left(\frac{M_x}{M_y} \right)^2 \right]^{1/2}$$

Reduction Factor

$$W_f = 4M'\theta$$



How to Create Shear Panel Elements?

External Work

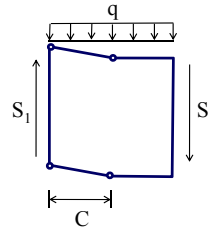

$$W_q = q \left(L - \frac{1}{2}C \right) \Delta$$

L: Half length of the beam



How to Create Shear Panel Elements?

Collapse stage

Internal work = External work

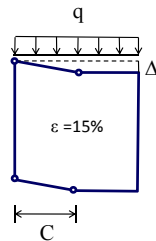
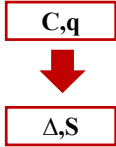

Collapse stage



Results and Validation

Ambient Temperature

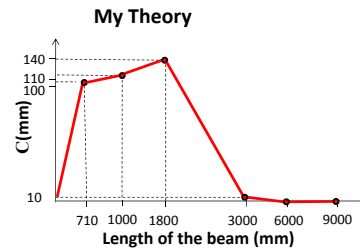

ABAQUS Model

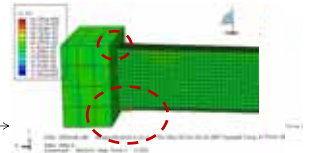

Results and Validation

Ambient Temperature

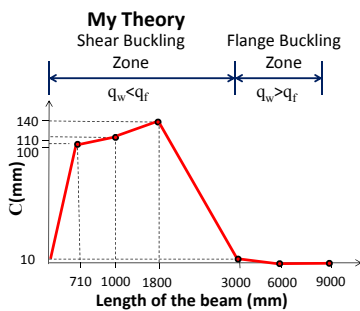

ABAQUS Model

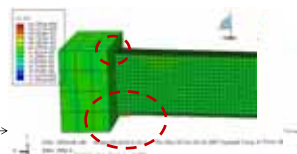

Results and Validation

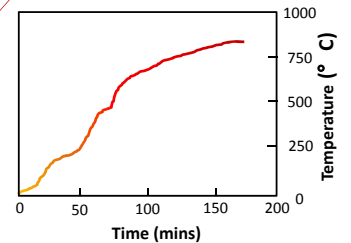
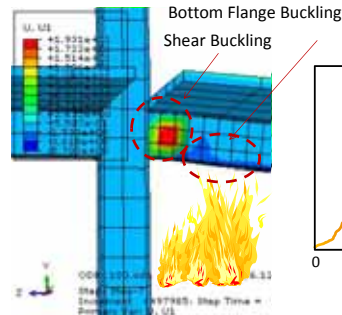

Results and Validation

Ambient Temperature

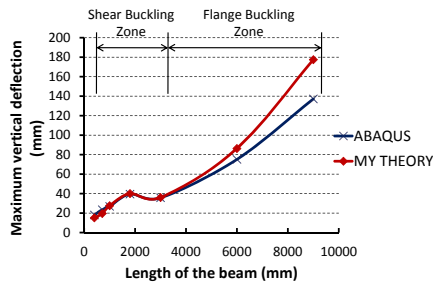

Results and Validation

Ambient Temperature

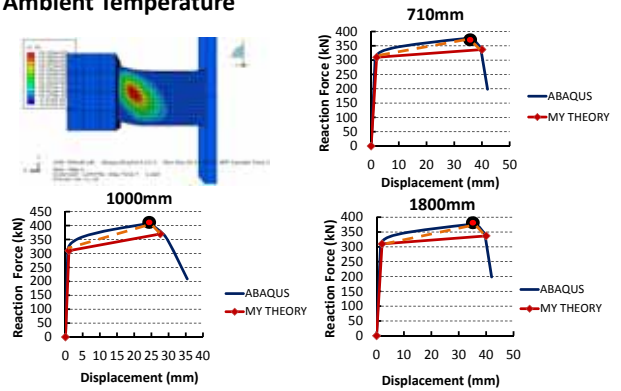

Next Step

Modelling Shear Panel Elements at Elevated Temperature

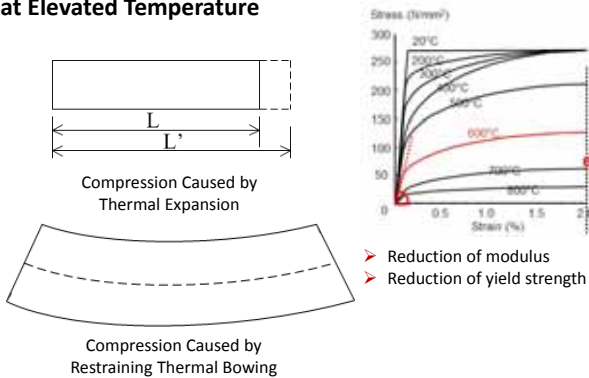

Next Step

Modelling Shear Panel Elements at Elevated Temperature

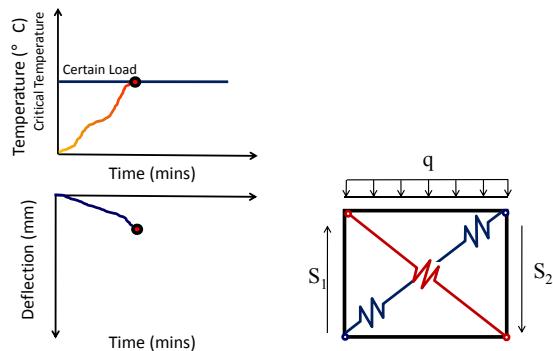

Next Step

Modelling Shear Panel Elements at Elevated Temperature

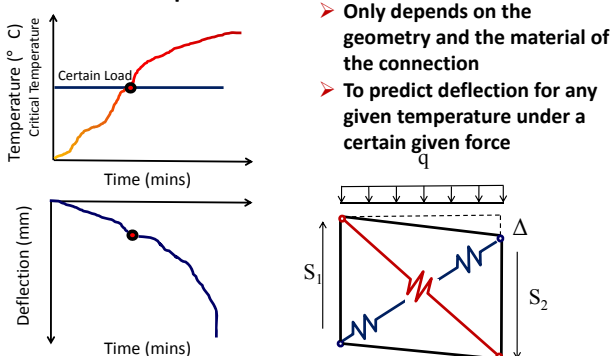

Problems and Discussions

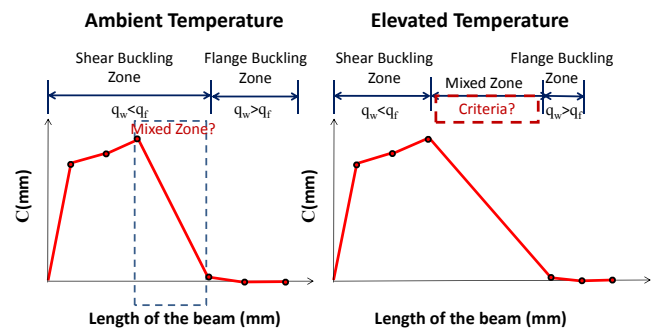



Thanks for your attention!

Email: g.quan@sheffield.ac.uk